

XR0TOR-2812SL 1100KV Specification (规格)

Rated Voltage(LiPo) 工作额定电压 (LiPo)	4-6S	KV KV值	1100KV
No-Load Current 空载电流	1.88A/24V	Resistance 相间内阻	46.6mΩ
Maximum Continuous Current 最大连续电流	64.1A/10s	Motor Weight 电机重量	83.8g
Maximum Continuous Rating 最大连续功率	1538W/10s	Pole/Slot 槽极数	12N14P
Maximum propeller pull 最大螺旋桨拉力	3722g	Motor Lead Type 线号	18AWG
Motor Size 电机尺寸	Φ 34 *25.5mm	Motor Lead Length 出线长度	250mm
Shaft Diameter 出轴直径	D5+H5	Enamelled Wire Insulation Class 漆包线绝缘等级	耐200°C高温 H级
Shaft Length 出轴长度	15mm	Recommended ESC 推荐电调	XRotor FPV-G2-65A-4in ECS
Screw Diameter / Thread 底座螺纹	Φ 19mm-4*M3	Propeller 螺旋桨	4-6S:HQ8x4.5x3R

Load Performance 负载性能参数

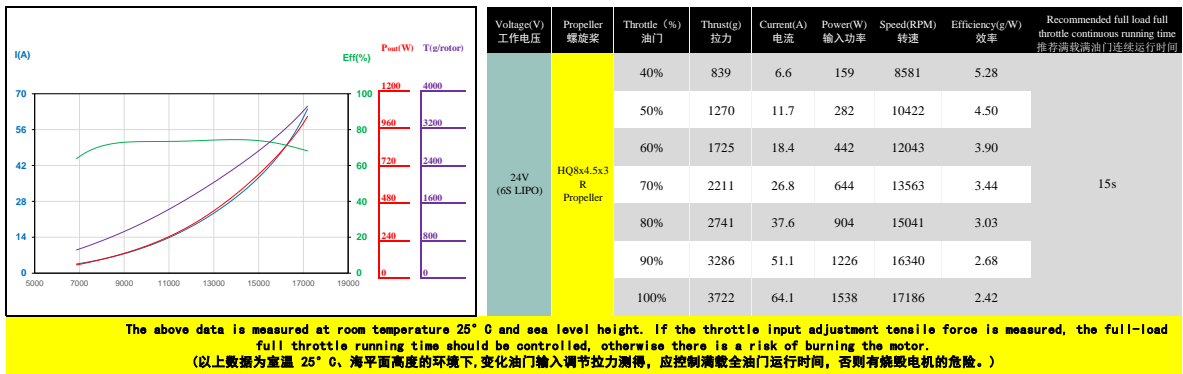

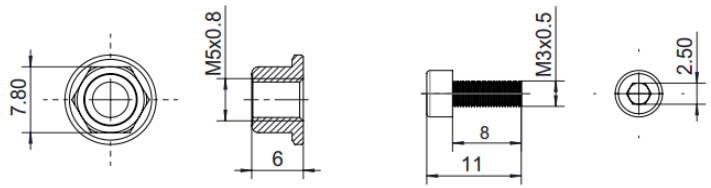
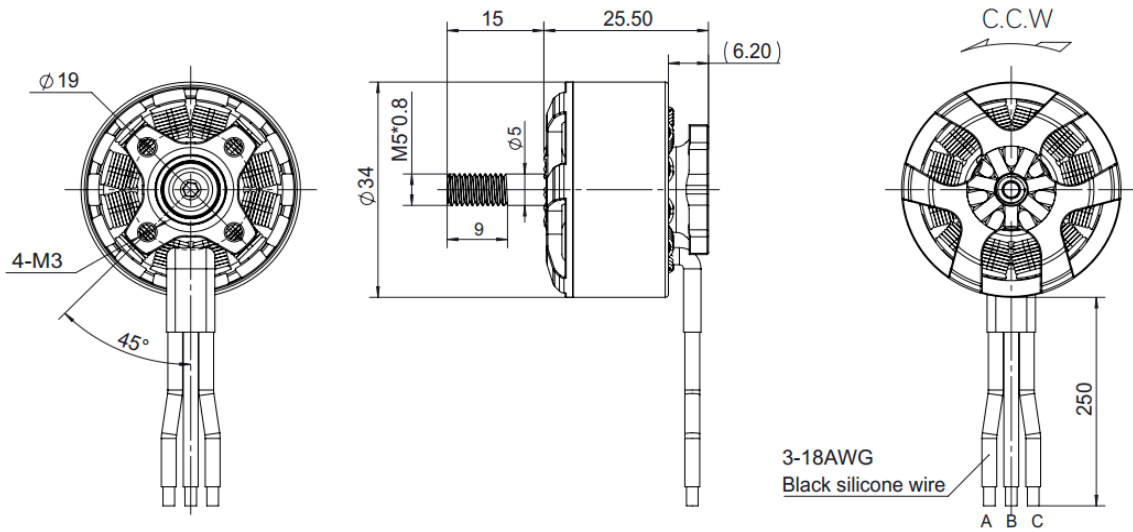

2812SL