

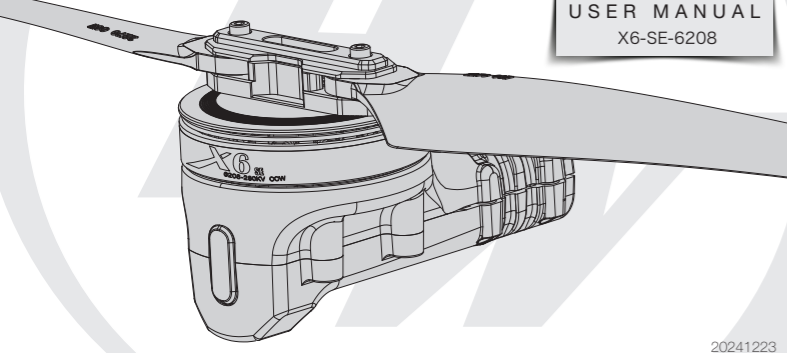

Thank you for purchasing this product! Please read the following statement carefully before use and, once used, it is considered to be an acceptance of all the contents. Please strictly observe and adhere to the manual installation with this product. Unauthorized modification may result in personal injury and product damage. We reserve the rights to update the design and performance of the product without notice.



20241223

HW-SMC907DULO

## 01 Introduction

The CM-X6-SE brushless power system is an industrial version power system that adopts a single-axis load of 2.0-2.5 kg. The maximum pulling force of a single axis is 6.2 kg and is suitable for a 25 mm carbon fiber tube arm with an overall waterproof level protection rated at IP43. The efficient heat dissipation provides a one-stop power solution for education and training, aerial photography, flight practice and other fields of small multi-rotor UAV applications. FOC ESC adopts CAN communication, dual redundant design of digital throttle and PWM throttle, with power-on self-test, fault storage, over-current protection, stall protection and other protection functions.

## 02 Precautions

- Please stay away from crowds, high-voltage lines, obstacles, etc. when using, and be sure to follow safety regulations when using.
- The power system contains BLDC drive ESC. We recommend to use the HF 22\*7.0" folding propellers of HOBBYWING, and can also be compatible with 22 inch of third-party manufacturers propellers, too large size may cause excessive load and out of step or other problems.
- The ESC is equipped with CAN function. When using the CAN function, the ESC ID and the throttle channel of the same aircraft cannot be the same, otherwise the multiple ESCs will be recognized as the same.
- Do not bring propellers for ground testing to avoid unnecessary danger.
- Be sure to connect all parts carefully. If the connection is poor, you may not be able to control the aircraft normally, or other unpredictable situations such as equipment damage may occur.
- If you need to weld the input and output wire plugs of the ESC, please ensure that the welding is reliable and use welding equipment with sufficient power.
- Do not use it when the external ambient temperature exceeds 65°C. The high temperature will destroy the ESC and may cause damage to the motor and cause the machine to explode.
- The steering of the power system has been set at the factory. Please observe the motor steering mark. It is not supported to change the sequence of the motor phase wires due to the packaging and sealing process.

## 03 Power system composition

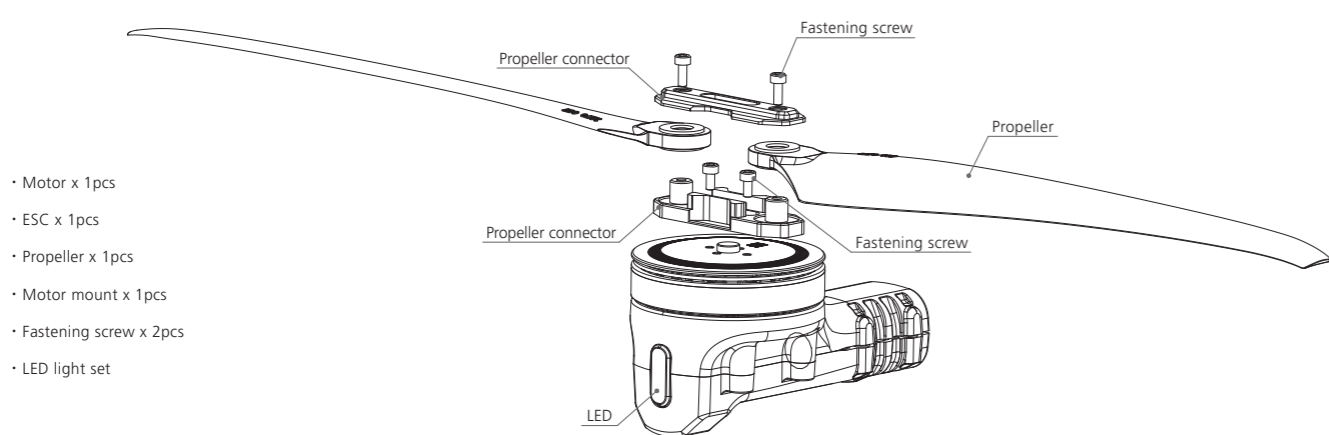

- Motor x 1pcs
- ESC x 1pcs
- Propeller x 1pcs
- Motor mount x 1pcs
- Fastening screw x 2pcs
- LED light set

## 04 Power system installation

- The entire power system has been assembled at the factory and can be taken out directly from the package to install on the UAV frame according to the rotation of the motor.
- The red and gray color cable is the data output and upgrade signal cable (the system can be upgraded for the ESC), the red wire is CAN-High (hereinafter referred to as CH); the gray wire is CAN-Low (hereinafter referred to as CL); The black and white cable is the ESC throttle signal wires, the black wire is the ground wire, and the white wire is the throttle signal wire.
- The data signal line outputs throttle, motor speed, bus current, bus voltage, capacitor temperature, MOS tube temperature and other data in real time.
- The ESC accelerator is solidified at 1100-1940μs.

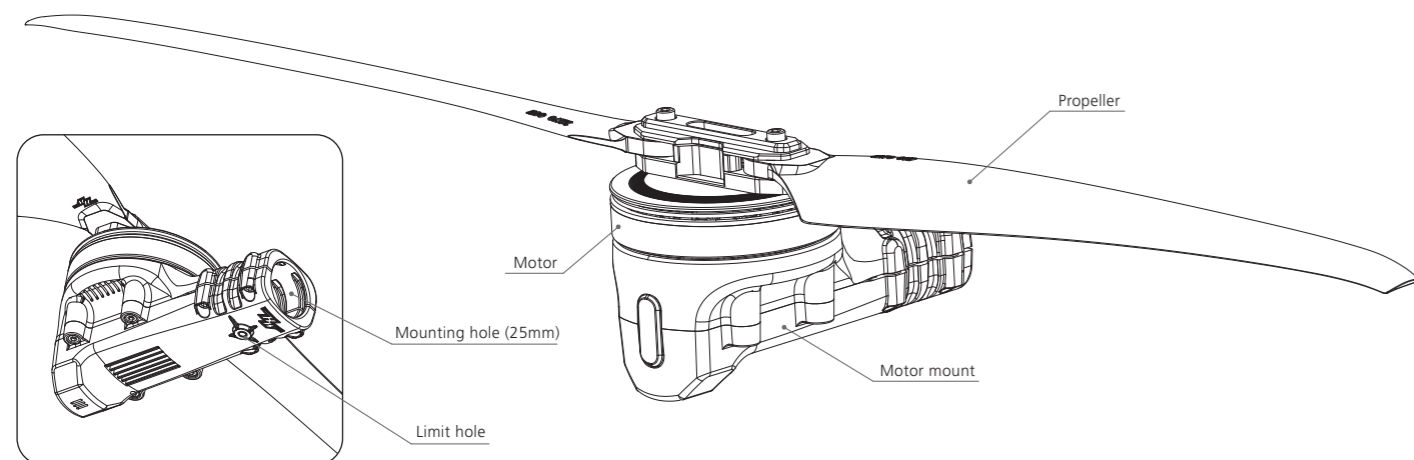

## 05 Specifications

Recommended uniaxial load: 2.2kg  
Max.Torque: 6.2 kg  
Lithium compatible: 6 S (LiPo) (MAX 27 V)  
Ambient temperature: -20°C-50°C  
Applicable carbon tube: 25mm (diameter)  
Total weight (excluding propellers): 373±15g  
Protection level: IP43  
Support throttle frequency: 50-500Hz

**ESC**  
Continuous current: 30A (Unconfined ambient temperature <60°C)  
Lithium compatible: 6S  
Instantaneous current: 60A (3 seconds - good heat dissipation)  
Throttle solidified: 1100-1940μs

**Motor**  
Model: 6208  
Outer diameter: Ø68.7\*25.8mm  
KV rating: 280KV

**Propeller**  
Dimension: 22\*7.0"  
Weight (straight propeller): 66g

## 06 Power system parameters

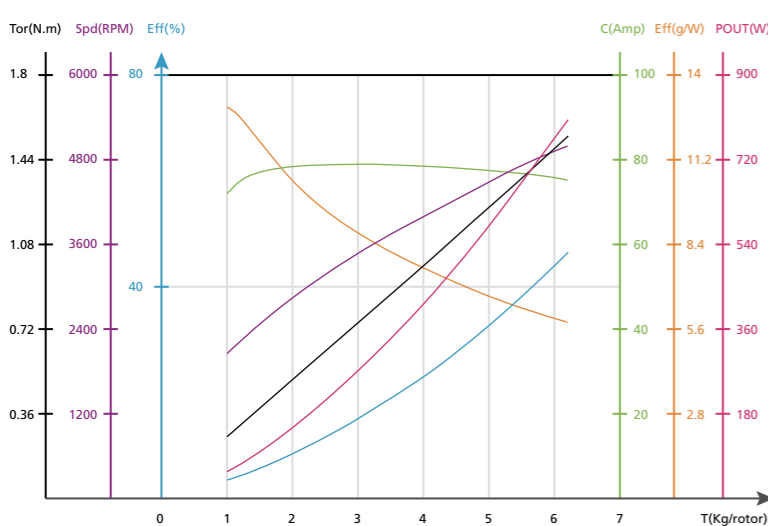

Voltage(V)	Propeller	Throttle(%)	Thrust(g)	Current(A)	Power(W)	Speed(RPM)	Efficiency(g/W)	Torque(N.m)	Temperature(°C)
23V (6S LiPo)	22*7.0"	33%	1076	3.6	83.8	2105	12.8	0.28	72°C
		35%	1209	4.2	96.1	2220	12.6	0.31	
		37%	1351	4.8	110.7	2340	12.2	0.34	
		39%	1500	5.5	127.2	2461	11.8	0.38	
		42%	1733	6.7	155.3	2642	11.2	0.44	
		45%	1974	8.1	186.8	2819	10.6	0.50	
		48%	2219	9.6	221.0	2988	10.0	0.55	
		51%	2467	11.2	257.6	3149	9.6	0.62	
		54%	2717	12.9	296.3	3301	9.2	0.68	
		57%	2969	14.6	337.2	3447	8.8	0.74	
		60%	3223	16.5	380.3	3588	8.5	0.80	
		63%	3480	18.5	425.9	3724	8.2	0.86	
		66%	3740	20.6	474.3	3858	7.9	0.92	
		69%	4003	22.8	526.0	3990	7.6	0.99	
		72%	4269	25.2	581.2	4122	7.3	1.05	
		75%	4538	27.8	640.0	4254	7.1	1.12	
		78%	4807	30.5	701.9	4385	6.8	1.19	
		81%	5073	33.3	766.4	4513	6.6	1.25	
		84%	5331	36.1	832.0	4634	6.4	1.32	
		87%	5577	38.9	896.5	4746	6.2	1.38	
90%	5800	41.6	956.9	4842	6.1	1.44			
100%	6207	46.4	1069.1	4996	5.8	1.54			

The above data are measured by Hobbywing Lab at the ambient temperature of 25°C and sea level by changing the throttle input adjustment. The motor temperature is measured by running the throttle at the rated point for 10 minutes, for reference only.

## 07 ESC protection function

This ESC is specially designed for industrial drones, without low-voltage protection and over-heat protection.

- Stall protection**  
When the ESC detects that the motor is locked, the ESC will completely turn off the output and repeatedly try to restart the motor. Please land the aircraft as soon as possible if the motor is unable to be restarted. The power output can only be resumed after the power is turned off and restarted, and the fault is eliminated.
- Current protection**  
When the instantaneous phase current abnormally reaches 202A, the ESC will turn off the output and keep trying to restart the motor. If the motor does not restart, it will return to normal after power on again.
- Over-heat warning**  
A fault message will be sent out through the data interface when the MOS is higher than 110°C or capacitor temperature is higher than 100°C. Please land the aircraft in time or reduce the throttle output when the ESC reports an over-heat fault, if the temperature continues to rise, electronic components may be damaged.
- Low voltage protection**  
This ESC has no low-voltage protection. Some electronic components of the ESC will work abnormally when the voltage falls below 9V. Please land the aircraft in time.
- Throttle signal loss protection**  
When the ESC detects that the throttle signal is lost, the output will be turned off immediately to avoid greater losses caused by the continued high-speed rotation of the propeller. After the signal is restored, the ESC will resume normal operation immediately.

## 08 ID setting

If there is no requirement, the default factory ID of the ESC is 1, the throttle channel is 1, and the bus speed is 500KHz. This function requires the additional purchase of DataLink data box. Before using this function, ensure that the computer system has installed Microsoft Visual C++ 2013 software in advance, otherwise it cannot operate normally.

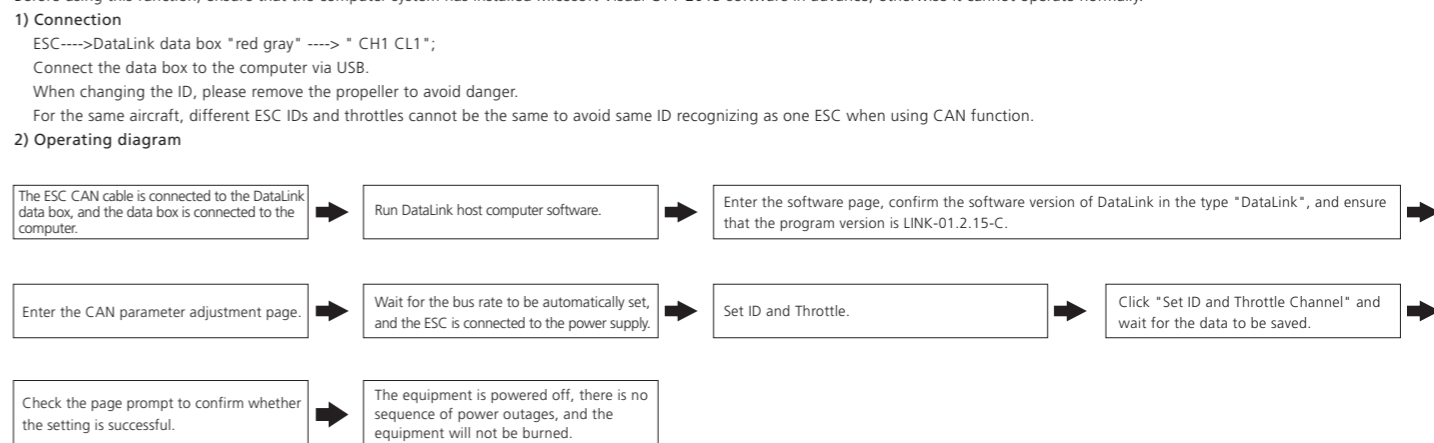

## 09 Fault data read

The ESC has its own fault storage function to store the times upon powering-on, flight time, and fault times information. It is convenient for flight fault analysis. This function needs to use DataLink data box, serial port assistant, and DataLink host computer software.

Note: DataLink software can be obtained from Hobbywing official website, dealers, Hobbywing sales, and Hobbywing after-sales. DataLink data box firmware version requirements: LINK-01.2.15-C or later; serial port assistant requirements: USB to TTL protocol; DataLink host computer software requirements: fault storage version. It can be obtained on the official website, WeChat official account or after-sales service.

The DataLink box has three power supply methods (+5V), USB data cable, serial port assistant, and external power supply cable. You can choose one of the power supply methods, and you don't need to repeat the power supply. Note: For detailed steps, please refer to the DataLink user manual.

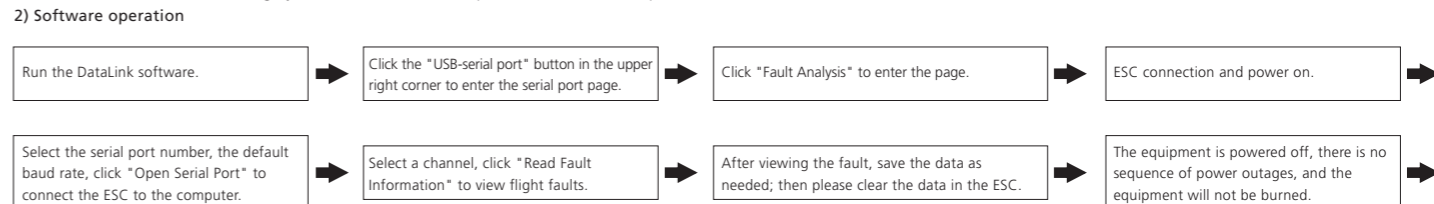

## 10 Firmware upgrade

Firmware upgrade is divided into two ways: computer online upgrade and flight controller remote upgrade. It supports online upgrade of multiple ESCs at the same time, and the upgrade port is CAN-ESC (Fast).

The upgrade of the flight control needs to cooperate with the flight control(not explained here). This function needs to use DataLink data box, special DataLink software for upgrade package, and USB data cable. DataLink data box version requirements, LINK-01.2.15-C or later; DataLink software can be obtained from Hobbywing official website, distributors, Hobbywing sales, and Hobbywing after-sales. Note: Please ensure that the computer system has installed Microsoft Visual C++ 2013 software before using this function, otherwise it cannot be used. An upgrade package usually only contains one program for one type of ESC. For other ESCs, please re-obtain the upgrade package for the corresponding ESC model.

**1) Connection**  
Connect the computer and the DataLink data box with the USB data cable; ESC---->DataLink data box "red gray" ----> " CH1 CL1".  
**2) Firmware acquisition**  
It can be obtained at the place of purchase, Hobbywing official website, dealers, Hobbywing sales and Hobbywing after-sales offices. Note: It can only be upgraded from the existing program, and software and hardware cannot be upgraded together.

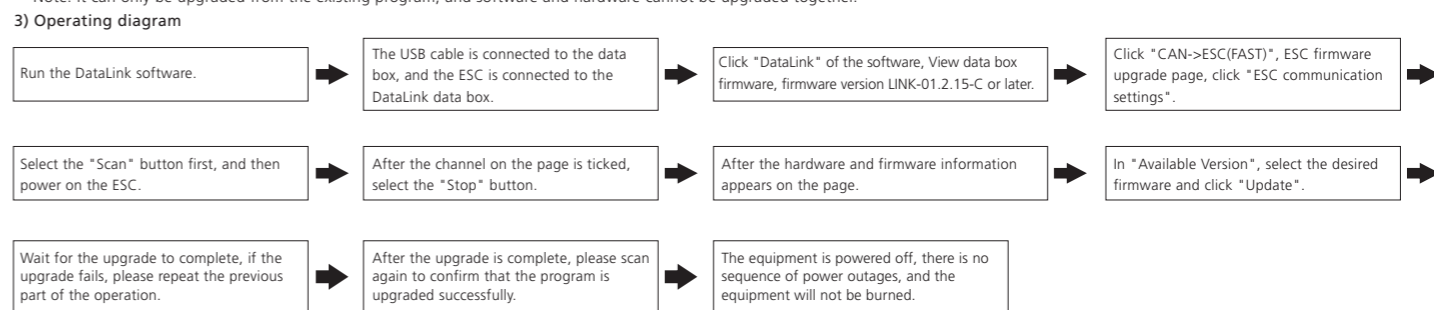

## 11 Common Faults and Prompt Sound Description

Warning tone description

Symptoms	Alarm tone	Possible causes	Solutions
Motor fails to start after power on	"Beep beep beep..." rapid monophonic	Throttle not reset to zero	Push the throttle to the lowest point or recalibrate the throttle point
Motor fails to start after power on	"Beep, beep, beep..." (1 second for each interval)	Receiver throttle channel has no throttle signal output	1. Check whether the transmitter and receiver operates normally 2. Check whether the throttle control channel wiring is normal
The power-on voltage is lower than 9V	"Beep, beep" (interval 1 second)	Battery voltage is too low	Replace with a suitable fully charged battery
The power-on voltage is higher than 27V	"Beep, beep" (interval 1 second)	Battery voltage too high	Replace with a suitable fully charged battery
The motor stops or restarts		The motor is not compatible with the ESC	Replace the motor, or replace the propeller
There is no sound during the self-test of the motor, but the motor can rotate	There is no prompt sound during self-test, and the motor rotates	Driver exception	1. Replace ESC 2. Return to factory for repair
The motor cannot start normally, accompanied by "click" "click" jitter	There is no prompt sound during the self-test, and the motor is unable to rotate	Motor phase loss	1. Check phase connection 2. Check motor 3. If there is no problem with the motor and connection, return the ESC to the factory for repair

## 12 The blinking of the light

Condition	normal	Full of throttle	Over voltage	Low voltage	Over current	Throttle lost	The input throttle signal is not at the 0% position	MOS overheat	Capacitor over heat	Motor block
Number of blinking of the light	The light is always on	Continuous short blinking	1 short	2 short	3 short	1 long	1 long and 1short	1 long and 2 short	1 long and 3 short	1 long and 4 short
Others										
Condition	The input throttle signal is not at the 0% position			Shorted circuit of signal line			Open circuit of motor			
Sound & blinking	Continus short loudly beep & LED continuous short blinking			Continuous short with blinking & LED off with LED off			Continus short blinking without beep			