

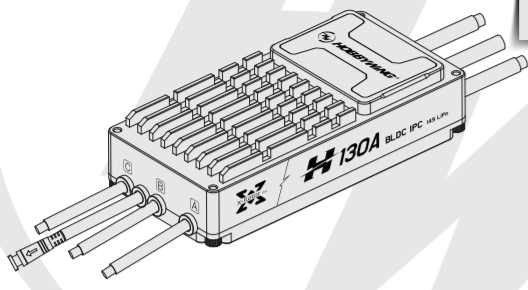

Thank you for purchasing this product! Please read the following statement carefully before use and, once used, it is considered to be an acceptance of all the contents. Please strictly observe and adhere to the manual installation with this product. Unauthorized modification may result in personal injury and product damage. We reserve the rights to update the design and performance of the product without notice.



H130A-14S-BLDC-IPC-RTF
USER MANUAL



20240304

HW-SMA849DUL00

01 Precaution

- Before connecting ESC to the related components, please ensure that all contact terminals are well insulated to prevent short circuit from damaging the ESC.
- Ensure proper connection for the aircraft to operate normally and prevent unpredictable damage to the equipment.
- Before using this ESC, please review the manual to ensure that the power system is correctly matched to avoid damage to the ESC due to wrong connectivity.
- Use only hi-power soldering station that is reliable for soldering work on the ESC.
- Do not use it when the external ambient temperature exceeds 65°C. The high temperature will destroy the ESC and may cause damage to the motor, and cause the machine to explode
- If you need to change the direction of rotation of the motor, you can change the sequence of any two-phase wires.
- The ESC is equipped with CAN function. When using the CAN function, the ESC ID and the throttle channel of the same aircraft cannot be the same, otherwise, the multiple ESCs will be recognized as the same.
- The ESC does not come with CAN terminal resistor by default and needs to be matched uniformly across the whole machine.

02 Feature of product

- This ESC has a fixed propeller function. In order to use this function, it needs to be paired with a Hobbywing motor with a magnetic encoding board.
- Multi-rotor dedicated core program, the throttle response speed is greatly improved.
- A built-in memory chip that records the ESC running data in real time and provides the black box function.
- This ESC is equipped with nano-coating technology with a protection level of IP55, and IP67 can be customized.
- The microprocessor is powered by an independent voltage regulator IC, which has better anti-interference ability and greatly reduces the possibility of control loss.
- Uses shielded wires to improve anti-interference, shield external and self-interference, and improves signal quality.
- BLDC square wave drive technology, good compatibility, a program can be compatible with a variety of motors.
- Using CAN communication, the input and output throttle, motor speed, bus current, bus voltage, capacitor temperature, MOS temperature, ESC status and other data can be monitored in real time. The communication protocol can be obtained by contacting Hobbywing.
- The factory default settings can meet the requirements of most applications with automatically adjustable timing, and is highly intelligent.
- Compatible with various flight controllers and throttle signals with a refresh rate of 50~500Hz.
- Using DEO (Driving Efficiency Optimization) drive technology, it has better throttle linearity and higher drive efficiency.
- You can use DataLink (optional) to upgrade the ESC program. For details, refer to the Datalink instruction manual or contact the manufacturer.
- Support flight controller upgrade ESC firmware. (Requires the use of flight controller)
- Throttle pulse width 1100-1940µs, solidified pulse width, not calibrated.

03 Product Specifications

Model	Continuous current Cooling wind speed 7m/s	Specification	BEC	Number of lithium battery cells(3.7V)	parameter options	Weight (no wire)	Physical dimension (mm)
XRotor Pro-H130A-14S-BLDC-IPC-RTF-HW-V2	60A	130A	None	6-14S	Unable to change parameters	148g	96.5x46x23.5

04 User Guide

Warning! The throttle of this ESC is fixed, and the throttle stroke cannot be calibrated.
Warning! This ESC has PWM throttle mode, CAN digital throttle mode, set which throttle mode to use, and the default response corresponds to the throttle mode.

Wiring method:

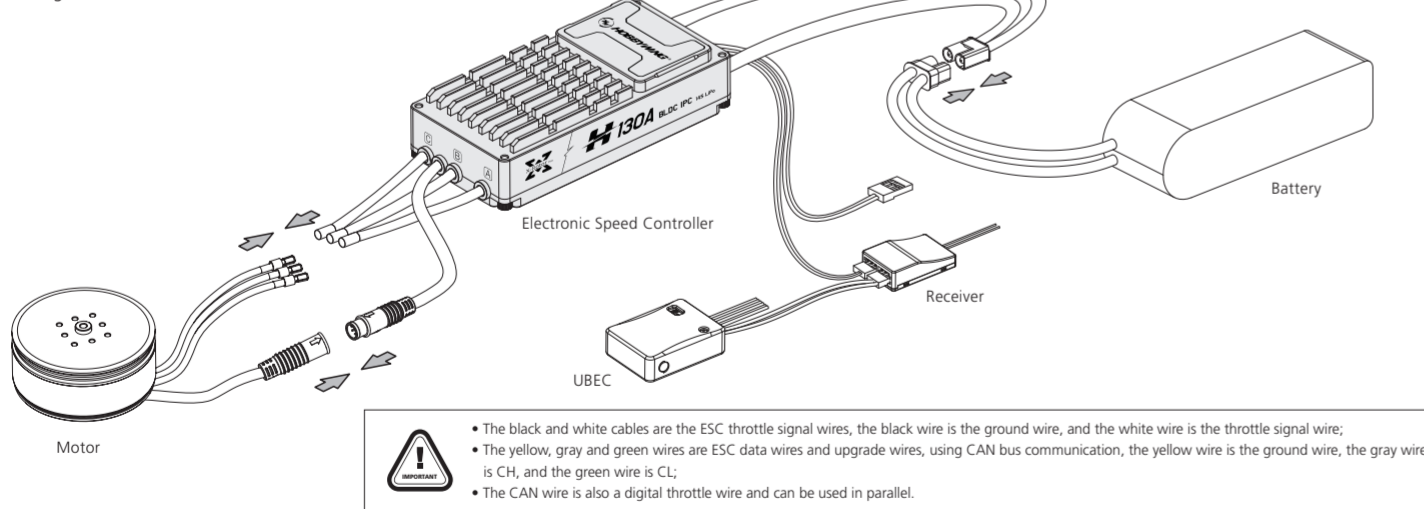

05 Normal start-up process

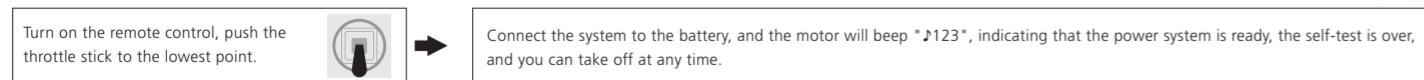

06 Protection function description

This ESC is specially designed for industrial drones without low-voltage protection and over-heat protection.

- 1) Start protection:
When the motor fails to start normally within two seconds after pushing the accelerator, the ESC will shut down and the throttle stick must be placed at the lowest point again before it can be restarted. (The reason for this may be poor connection between the ESC and the motor or disconnected individual output wires, motor stalled, propeller blocked, etc.).

- 2) Stall protection:
The ESC will completely shut down the output after 2 seconds and repeatedly try to restart the motor when it detects that the motor is stalled. If the motor fails to restart, please troubleshoot carefully and restart before power output can be restored.
- 3) Current protection:
The ESC will shut down the output and keep trying to restart the motor when the instantaneous current is abnormal and exceeds 500A. If the motor fails to restart multiple times, it will return to normal after restart.
- 4) Over-heat warning:
This ESC has no over-heat protection. The warning will be sent through the data interface when temperature is too high and when it is more than 110°C. When the temperature of the ESC is higher than 130°C, electronic components may be damaged. Please land the aircraft immediately or reduce the throttle output.
- 5) Low voltage protection:
This ESC has no low-voltage protection. Some electronic components of the ESC will work abnormally when the voltage falls below 18V. Please land the aircraft immediately.
- 6) Throttle signal loss protection:
When the ESC detects that the throttle signal is lost, the output will be turned off immediately to avoid greater losses caused by the continued high-speed rotation of the propeller. After the signal is restored, the ESC will resume normal operation immediately.

07 ID Setup

If there is no requirement, the default factory ID of the ESC is 1, the throttle channel is 1, and the bus speed is 500KHz. This function requires the additional purchase of DataLink data box. Before using this function, ensure that the computer system has installed Microsoft Visual C++ 2013 software in advance, otherwise it cannot operate normally.

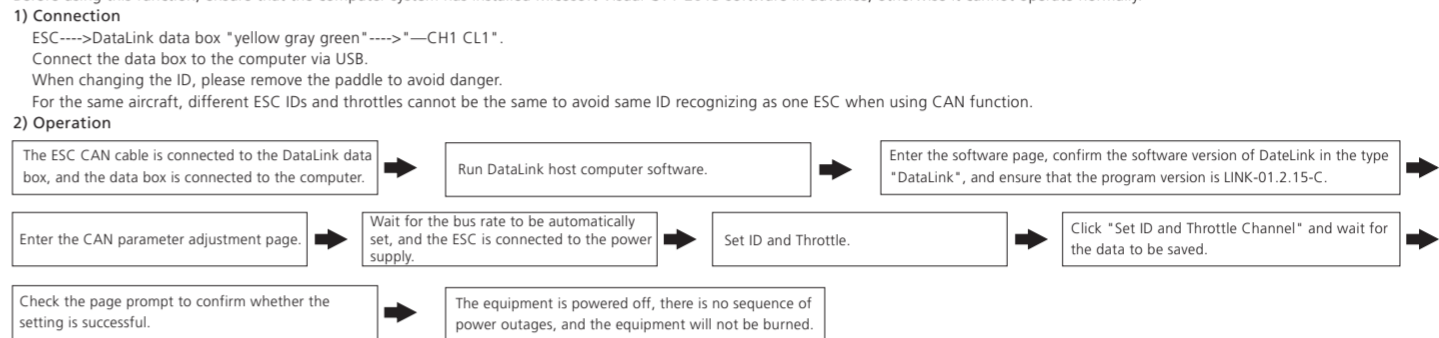

08 Firmware upgrade

Firmware upgrade is divided into two ways: computer online upgrade and flight controller remote upgrade. It supports online upgrade of multiple ESCs at the same time, and the upgrade port is CAN-ESC (Fast). The flight control upgrade requires the use of flight control, and is not explained here. This function needs to use DataLink data box, special DataLink software for upgrade package, and USB data cable. DataLink data box version requirements, LINK-01.2.15-C or later; DataLink software can be obtained from Hobbywing official website, distributors, Hobbywing sales, and Hobbywing after-sales. Note: Before using this function, please ensure that the computer has installed Microsoft Visual C++ 2013 software, otherwise it cannot be used. An upgrade package usually only contains one program for one ESC. For other ESCs, please obtain a new upgrade package. For details, please refer to the DataLink user manual.

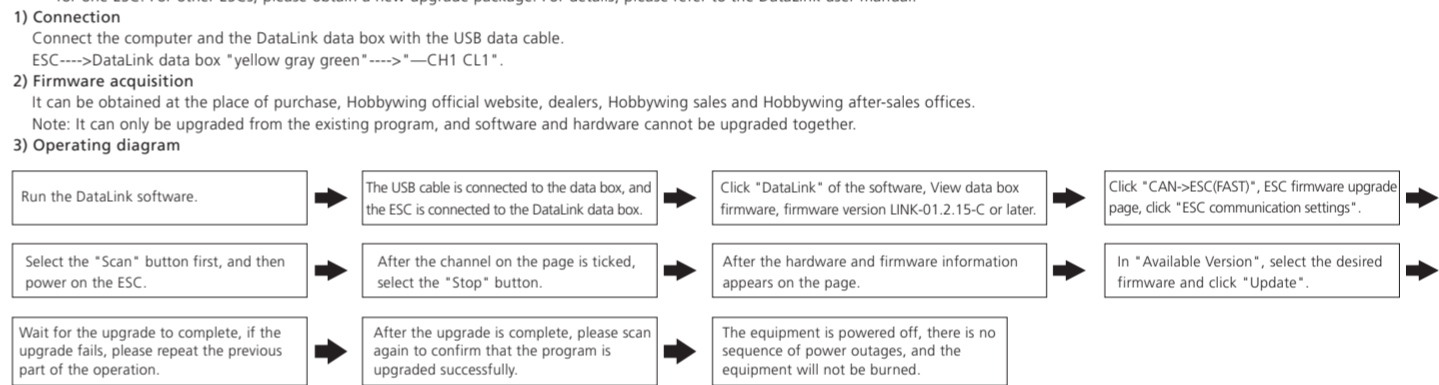

09 Common failures and workaround

Warning tone description

SYMPTOM	TONE	POSSIBLE CAUSES	POSSIBLE SOLUTIONS
Motor fails to start after power on	"Beep beep beep..." rapid monophonic	Throttle not reset to zero	Push the throttle to the lowest point or recalibrate the throttle point
Motor fails to start after power on	"Beep, beep, beep..." (1 second for each interval)	Receiver throttle channel has no throttle signal output	Check whether the transmitter and receiver operates normally Check whether the throttle control channel wiring is normal
The power-on voltage is lower than 18V	"Beep, beep" (interval 1 second)	Battery voltage is too low	Replace with a suitable fully charged battery
The power-on voltage is higher than 65V	"Beep, beep" (interval 1 second)	Battery voltage too high	Replace with a suitable fully charged battery
The motor stops or restarts		The motor is not compatible with the ESC	Replace the motor, or replace the propeller
There is no sound during the self-test of the motor, but the motor can rotate	There is no prompt sound during self-test, and the motor rotates	Driver exception	1. Replace ESC; 2. Return to factory for repair.
The motor cannot start normally, accompanied by "click" "click" jitter	There is no prompt sound during the self-test, and the motor is unable to rotate	Motor phase loss	1. Check phase connection; 2. Check motor; 3. If there is no problem with the motor and connection, return the ESC to the factory for repair.

10 Instructions for the use of fixed propeller function

This function requires the use of DataLink data box, dedicated DataLink host computer software, dedicated parameter configuration file, and USB-TTL module. Note: Please confirm that the USB-TTL module driver has been installed correctly; the DataLink data box version requirement is LINK-01.2.15-C or higher; before using this function, please ensure that the computer has installed Microsoft Visual C++ 2013 software. If it is not installed, it will not work. Please refer to the DataLink user manual for details.

