

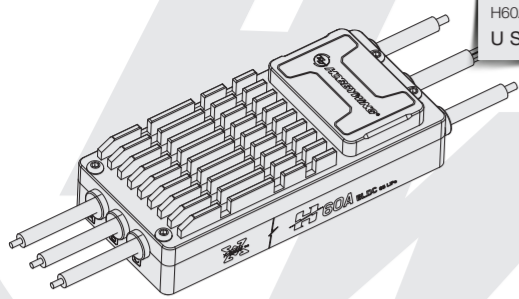

Thank you for purchasing this product! Please read the following statement carefully before use and, once used, it is considered to be an acceptance of all the contents. Please strictly observe and adhere to the manual installation with this product. Unauthorized modification may result in personal injury and product damage. We reserve the rights to update the design and performance of the product without notice.



X-ROTOR Pro
H60A-6S-BLDC-RTF-HW-V2
USER MANUAL



20231007

01 Precaution

- Before connecting ESC to the related components, please ensure that all contact terminals are well insulated to prevent short circuit from damaging the ESC.
- Ensure proper connection for the aircraft to operate normally and prevent unpredictable damage to the equipment.
- Before using this ESC, please review the manual to ensure that the power system is correctly matched to avoid damage to the ESC due to wrong connectivity.
- Use only hi-power soldering station that is reliable for soldering work on the ESC.
- Do not use it when the external ambient temperature exceeds 65°C. The high temperature will destroy the ESC and may cause damage to the motor, and cause the machine to explode
- If you need to change the direction of rotation of the motor, you can change the sequence of any two-phase wires.
- The ESC is equipped with CAN function. When using the CAN function, the ESC ID and the throttle channel of the same aircraft cannot be the same, otherwise, the multiple ESCs will be recognized as the same.
- The ESC doesn't have the CAN terminal resistor.

02 Feature of product

- Multi-rotor dedicated core program, the throttle response speed is greatly improved.
- A built-in memory chip that records the ESC running data in real time and provides the black box function.
- This ESC is equipped with nano-coating technology with a protection level of IP55, and IP67 can be customized.
- The microprocessor is powered by an independent voltage regulator IC, which has better anti-interference ability and greatly reduces the possibility of control loss.
- Uses shielded wires to improve anti-interference, shield external and self-interference, and improves signal quality.
- BLDC square wave drive technology, good compatibility, a program can be compatible with a variety of motors.
- Using CAN communication, the input and output throttle, motor speed, bus current, bus voltage, capacitor temperature, MOS temperature, ESC status and other data can be monitored in real time. The communication protocol can be obtained by contacting Hobbywing.
- The factory default settings can meet the requirements of most applications with automatically adjustable timing, and is highly intelligent.
- Compatible with various flight controllers and throttle signals with a refresh rate of 50-500Hz.
- Using DEO (Driving Efficiency Optimization) drive technology, it has better throttle linearity and higher drive efficiency.
- You can use DataLink (optional) to upgrade the ESC program. For details, refer to the Datalink instruction manual or contact the manufacturer.
- Support flight controller upgrade ESC firmware. (Requires the use of flight controller)
- Throttle pulse width 1100-1940µs, solidified pulse width, not calibrated.

03 Product specification

Model	Continuous current Cooling wind speed 7m/s	Specification	BEC	Number of lithium battery cells (Standard voltage 3.7V)	Parameter options	Weight (without wire)	volume (mm)
XRotor Pro-H60A-6S-BLDC-RTF-HW-V2	40A	60A	None	4-6S	Unable to change parameters	53g	71 x 32.2 x 16.2

04 User Guide

Warning! The DEO function of is default turned on, and closing the throttle has a braking effect and reverse-series voltage. Please do not use a power supply device that cannot absorb reverse-series voltage for ESC testing, otherwise the ESC and power supply will be damaged.

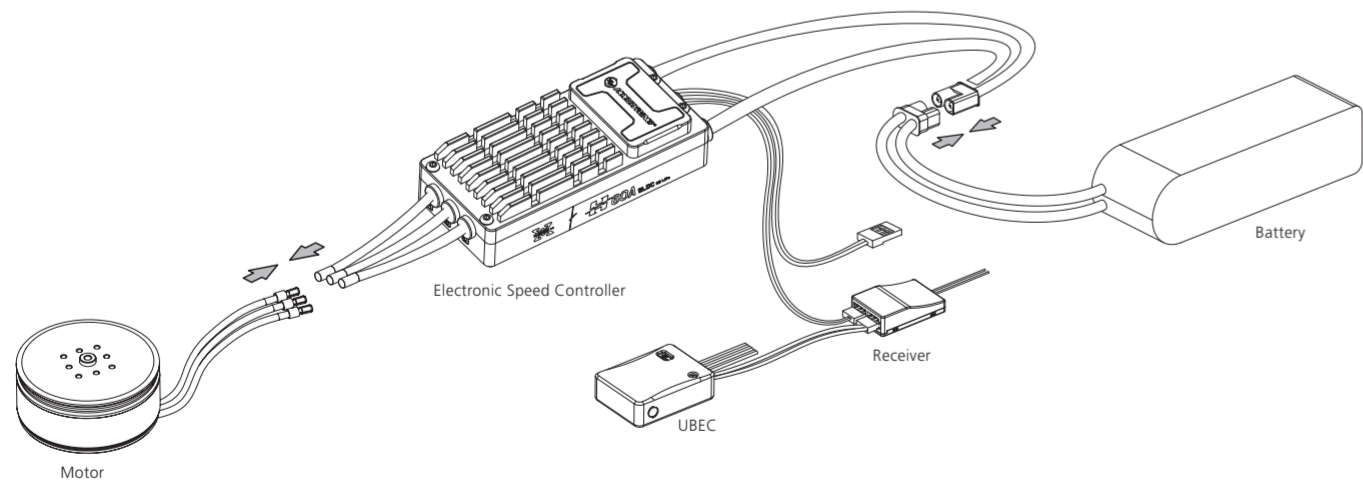

- The black and white wires are the ESC throttle signal cable, the black wire is the GND, and the white wire is the throttle signal wire;
- The yellow, gray and green wires are the ESC data cable and upgrade cable, using CAN bus communication, the yellow wire is the GND, the gray wire is CH, and the green wire is CL;
- The CAN cable is also a digital throttle cable and can be used in parallel.

05 Normal boot process

Turn on the remote control, push the throttle stick to the lowest point.



Connect the system to the battery, and the motor will beep "♪123", indicating that the power system is ready, the self-test is over, and you can take off at any time.

06 Protection function description

This ESC is specially designed for industrial drones without low-voltage protection and over-heat protection.

- 1) Start protection:**
When the motor fails to start normally within two seconds after pushing the accelerator, the ESC will shut down and the throttle stick must be placed at the lowest point again before it can be restarted. (The reason for this may be poor connection between the ESC and the motor or disconnected individual output wires, motor stalled, propeller blocked, etc.).
- 2) Stall protection:**
When the ESC detects that the motor is blocked, the ESC will completely turn off the output and repeatedly try to restart the motor. If failed restart, please check the faults. The power output can only be resumed after the power is turned off and restarted, and the fault is eliminated.
- 3) Current protection:**
When the instantaneous phase current is over 300A, the ESC will turn off the output and keep trying to restart the motor. If the motor does not restart, it will return to normal after power on again.
- 4) Over-heat warning:**
This ESC has no over-heat protection. The warning will be sent through the data interface when temperature is too high and when it is more than 110°C. When the temperature of the ESC is higher than 130°C, electronic components may be damaged. Please land the aircraft immediately or reduce the throttle output.
- 5) Low voltage protection:**
This ESC has no low-voltage protection. Some electronic components of the ESC will work abnormally when the voltage falls below 12V. Please land the aircraft immediately.
- 6) Throttle signal loss protection:**
When the ESC detects that the throttle signal is lost, the output will be turned off immediately to avoid greater losses caused by the continued high-speed rotation of the propeller. After the signal is restored, the ESC will resume normal operation immediately.

07 ID setting

If there is no requirement, the default factory ID of the ESC is 1, the throttle channel is 1, and the bus speed is 500KHz.

This function requires the additional purchase of DataLink data box.

Before using this function, ensure that the computer system has installed Microsoft Visual C++ 2013 software in advance, otherwise it cannot operate normally.

1) Connection

ESC---->DataLink data box "yellow gray green"---->"—CH1 CL1";

Connect the data box to the computer via USB.

When changing the ID, please remove the paddle to avoid danger.

For the same aircraft, different ESC IDs and throttles cannot be the same to avoid same ID recognizing as one ESC when using CAN function.

2) Operating diagram

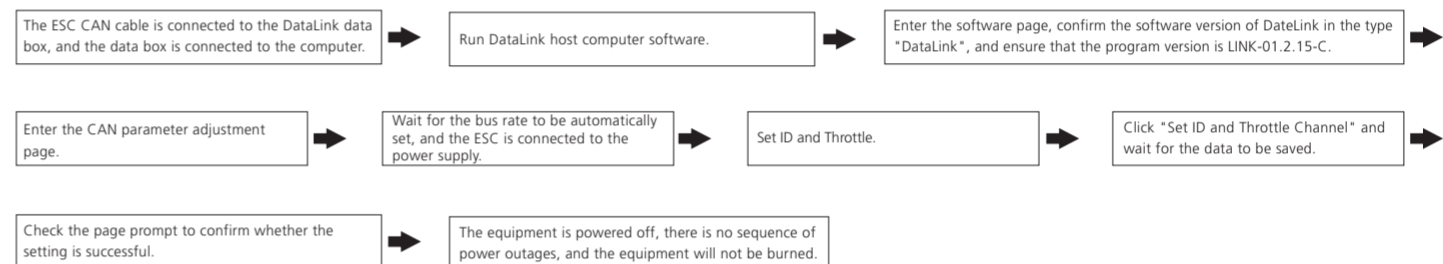

08 Firmware upgrade

Firmware upgrade is divided into two ways: computer online upgrade and flight controller remote upgrade. It supports online upgrade of multiple ESCs at the same time, and the upgrade port is CAN-ESC (Fast).

The flight control upgrade requires the use of flight control, and is not explained here.

This function needs to use DataLink data box, special DataLink software for upgrade package, and USB data cable.

DataLink data box version requirements, LINK-01.2.15-C or later; DataLink software can be obtained from Hobbywing official website, distributors, Hobbywing sales, and Hobbywing after-sales.

Note: Before using this function, please ensure that the computer has installed Microsoft Visual C++ 2013 software, otherwise it cannot be used. An upgrade package usually only contains one program for one ESC. For other ESCs, please obtain a new upgrade package. For details, please refer to the DataLink user manual.

1) Connection

Connect the computer and the DataLink data box with the USB data cable.

ESC---->DataLink data box "yellow gray green"---->"—CH1 CL1".

2) Firmware acquisition

It can be obtained at the place of purchase, Hobbywing official website, dealers, Hobbywing sales and Hobbywing after-sales offices.

Note: It can only be upgraded from the existing program, and software and hardware cannot be upgraded together.

3) Operating diagram

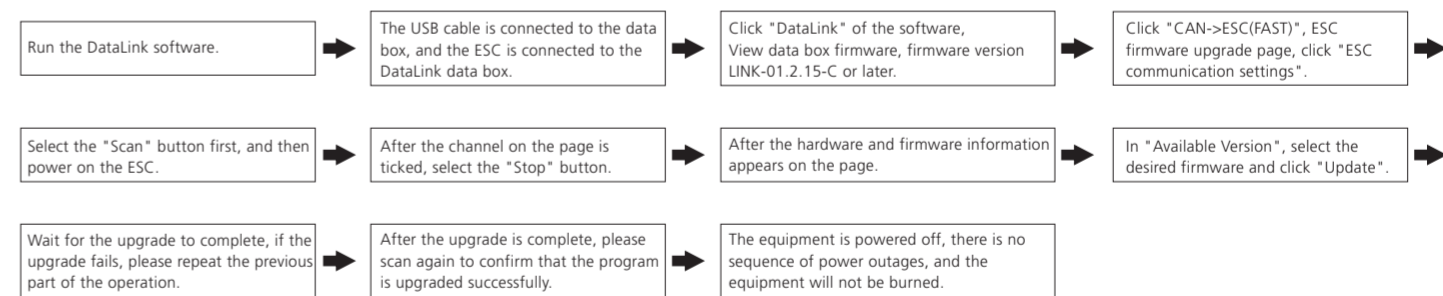

09 Common Faults and Prompt Sound Description

Warning tone description.

SYMPTOM	TONE	POSSIBLE CAUSES	POSSIBLE SOLUTIONS
Motor fails to start after power on	"Beep beep beep" rapid monotone	Throttle is not reset to zero	Push the throttle to the lowest point or recalibrate the throttle point.
Motor fails to start after power on	"Beep, Beep, Beep" (1 second for each interval)	No throttle signal input on the receiver throttle channel.	Check if transmitter and receiver is normal. Check if wiring of throttle channel is normal.
The power-on voltage is lower than 12 V	"Beep, Beep, Beep" (1 second for each interval)	Battery voltage is too low.	Replace with a full-charged battery.
The power-on voltage is higher than 27 V	"Beep, Beep, Beep" (1 second for each interval)	Battery voltage is too high.	Replace with a suitable and fully-charge battery.
Motor stops or restarts during operation		Motor is not compatible with the ESC.	Replace motor, or propeller.
No sound during self-test, motor is operating	No sound during self-test, motor is operating	Abnormal drive.	1. Replace ESC; 2. Return to factory for repair.
Motor fails to start normally, accompanied by "jam" vibration	No sound during self-test, motor is not operating	Loss of motor phase.	1. Check phase connection; 2. Check motor; 3. Return to factory for repair.