

XERUN BANDIT G2 USER MANUAL

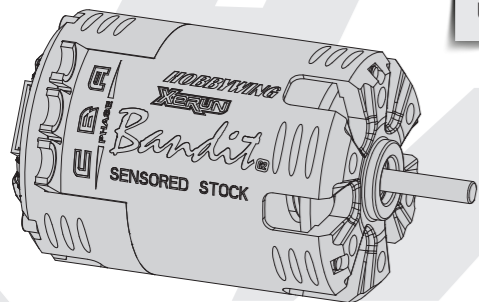

20161128

02 FEATURES

- Extreme powerful (the output power of BANDIT G2 motor is 20% higher than the standard V10 motors), specially designed for out-law STOCK races.
- Designed to withstand extreme levels of use at its highest peak performance.
- Complete new CNC cut motor case with extra front spoke ventilation slots.
- Works as a sensored unit and also sensorless without the sensor cable attached.
- Multiple steps of mechanical timing adjustable from 20 degree to 50 degree.
- Minimal maintenance is required with precise machining technology which ensures a minimum tolerance end play of the rotor shaft. Eliminating the copper shims used in most of today's motors.
- 200 C high temperature tolerance and high purity copper windings maximize conductivity and reliability.
- 200 C high temperature tolerance sintered NdFeb magnets.
- Extreme low resistance multi-layered outlet PCB and high RPM NSK bearings.
- **Note:** BANDIT G2 motor is compliant with IFMAR rules but not ROAR rules.

03 SPECIFICATIONS

PN	Model	KV Without Load (RPM/V)	Resistance (Ω)	Current Without Load (A)	Max. Output Power (W)	Current @Max. Output Power (A)	Dia. & Length (mm)	Dia. of External Shaft (mm)	Pole	Stock Rotor	Weight (g)	Application
30101151	4.5T	8100 KV	0.0043Ω	10.8A	400W	125A	Ø=36mm (1.417in)	Ø=3.17mm (0.125in)	2	Ø5-12.3-U	188g (6.632oz)	1/10 on-road Modified; 1/10 4WD off-road Modified
30101152	5.5T	6850 KV	0.0053Ω	8.8A	385W	120A					188g (6.632oz)	
30101156	10.5T	3800 KV	0.0122Ω	3.4A	325W	90A	L=52.5mm (2.067in)	L=14.6mm (0.575in)			188g (6.632oz)	1:10 drift cars, 1:10 touring cars for STOCK races
30101157	13.5T	3000 KV	0.0198Ω	2.4A	265W	73A					188g (6.632oz)	1:10 touring cars for STOCK races
30101158	17.5T	2300 KV	0.0345Ω	1.9A	200W	60A					188g (6.632oz)	1:10 touring cars F1 for STOCK races
30101159	21.5T	1900 KV	0.0535Ω	1.8A	155W	42A					188g (6.632oz)	

• The "Max. Output Power" is measured with 7.4V input voltage and ESC at ZERO timing. This parameter is neither the "maximum input power" nor the "rating power", it is calculated by "RPM x Torque / 9550". Because each factory runs a different testing platform, the above data may vary if the motor is tested in different factories running different testing platforms.

! The "Output Power" value shouldn't be compared with the "Input Power" value directly because the motor efficiency is always less than 100%, the value of "Output Power" is always smaller than the "Input Power".

- The "Current at Peak Output Power" is a guide used for selecting the suitable power system (ESC, Motor, Gear ratio, etc.) If the actual input current of the power system is bigger than the peak parameter stated in the above table, this means that the power system settings / configuration is over its peak (Or in other words, "overloaded")
- The "KV" is measured without any load on the motor and ESC at ZERO timing. Please don't run the motor without load for long periods of time (1 minute), otherwise the motor may overheat.

04 INSTALLATION AND CONNECTIONS

- Install the motor in its mount using M3 screws no longer than 8mm.
- There are 3 power wires coming from the ESC must be soldered to the motor. They are usually color coded as Blue for Wire A, Yellow for Wire B and Orange for Wire C. When connecting the power wires between the ESC and motor, please make sure that you match ESC Wire A to Motor Phase A, ESC Wire B to Motor Phase B and ESC wire C to Motor Phase C (This is VERY important).
- When using sensored ESC, make sure the sensor cable is clean and reliable. Connect the sensor cable to both ESC and motor in the correct direction.
- Double check you have all the connections correct before turning on the ESC (See connection diagram as below).

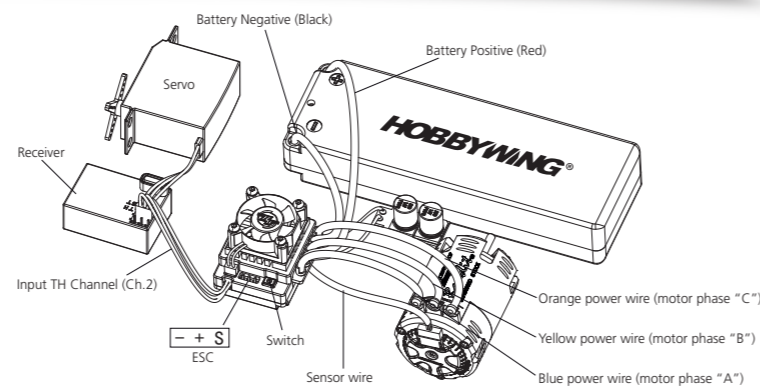

Thanks for purchasing Hobbywing Xerun BANDIT G2 Sensored Competition Motor. High power motor can be very dangerous, so please read through this manual carefully. Given that we have no control over the correct use, installation, application, or maintenance of our products, no liability shall be assumed nor accepted for any damages, losses or costs resulting from the use of the product.



Any claims arising from the operating, failure or malfunctioning etc. will be denied. We assume no liability for personal injury and/or consequential damages resulting from our product or our workmanship. As far as is legally permitted, the obligation to compensation is limited to the invoice amount of the affected product.

01 CAUTIONS

- Avoid incorrect connections between the electronic speed controller (ESC) and the motor.
- All wires and connections should be well insulated. Short-circuits can possibly damage the products.
- Never allow this product or other electronic components to come in contact with water, oil, fuel or other electro-conductive liquids. If this happens, stop the use of your product immediately and let it dry carefully.
- Avoid overloading the motor due to wrong or too aggressive gear ratios. Different ESCs have different internal timings, follow the ESC instructions.
- Never apply full throttle if the pinion is not installed. Due to the extremely high RPMs without load, the motor can get damaged.
- Always wire up all the parts of the equipment carefully. If any of the connections come loose as a result of vibration, your model RC may lose control.
- Avoid soldering longer than 5 seconds at each soldering joint when replacing the power wires to prevent possible damage to the product due to overheating of the components. Use a high power soldering station with at least 60W for soldering.
- Never allow the motor case to get over 80 degrees Celsius (176 degrees Fahrenheit) because the magnets maybe demagnetized by high temperature.

05 TIMING ADJUSTMENT

- To adjust the timing, simply loosen the 1 short screws on the back of the motor and rotate the Sensor Module Cover, noting the white-color lines on the motor and the mark (pointer) on the cover. After the adjustment, please lock the 2 short screws.
- You can adjust the timing on the motor to change the power-band and characteristics of the motor for best and the most efficient performance. Default timing is 30 degrees, and the motor has 20 degrees timing on minimum setting (fully clockwise) to maximum 50 degrees (fully anti-clockwise).
- Increasing the timing will increase the RPM of the motor whilst at the same time increasing temperatures and losing efficiency. Higher timing will require a slower gear ratio. We recommend you start with the default timing setting.
- When setting your motor timing it is important to make sure your ESC is also set correctly. Please follow your ESC instructions on how to do this. To check the motor temperatures during testing, simply drive for 3 laps of the track, stop and use an infrared temperature measuring instrument to make sure the motor is not too hot. If the motor is too hot then allow the motor to cool before trying it again.

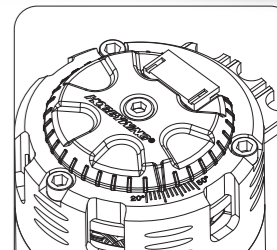

06 GEARING

Below is a very rough idea of starting gear ratios or Rollout for the motors. Please be aware that these are guide ratios for ESC with ZERO timing. Please always check with experienced drivers using the same ESC/Motor combination at your track for a good starting point.

Class	Battery	10.5T	13.5T	17.5T	21.5T
1/10 on-road (Small track)	7.4V LiPo	4.5:1	4.0:1	3.2:1	2.8:1
1/10 on-road (Big track)	7.4V LiPo	4.2:1	3.6:1	3.0:1	2.6:1
1/12 on-road	3.7V LiPo	42mm	51mm	60mm	66mm
1/10 F1	7.4V LiPo			56mm	62mm

07 ASSEMBLY AND DISASSEMBLY

The XERUN BANDIT G2 Motor is very strong in construction but also easy to disassemble for maintenance. We recommend periodical checking of the bearings and to clean the motor of dirt. Please follow the steps in below to assemble the motor. When disassembling the motor, the sequences are reversed. * Please browse Hobbywing web for high-resolution assembly drawings. www.hobbywing.com

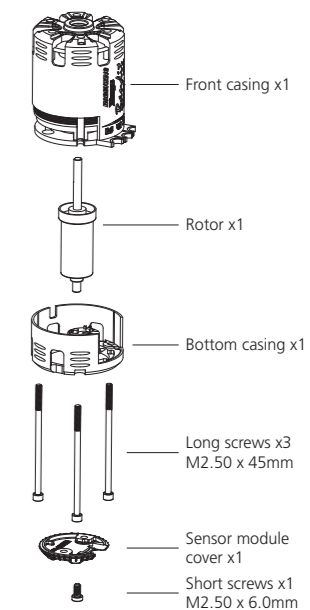
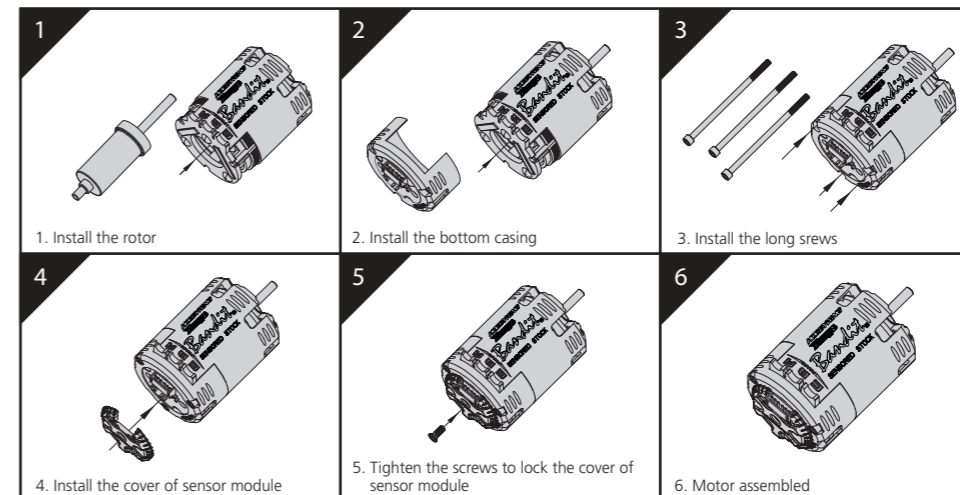

08 PARTS LIST

The XERUN BANDIT G2 Motor has the parts as below (Please also check picture 5 for reference).

- | | | |
|---|-----------------------------------|-------------------------------|
| 1) Ball bearing x 1 (13.175x9.525x3.967mm) | 2) Rotor x 1 | 3)Front casing x 1 |
| 4) Metal Bottom Case (w/ Sensor Module) x 1 | 5) Long screws x 3 (M2.50x45mm) | 6) Cover of sensor module x 1 |
| 7)Short screws 1 (M2.50x6.0mm) | 8) Sensor wires x 2 (80mm, 200mm) | |

09 OPTIONS

Spare Part	PN	Description	Specification
Ball bearing	30820001	540 MOTOR BEARING-3.175	R2ZZ Ball Bearing, 3.175x9.525x3.967mm
Rotor	30820012	XERUN-V10&BANDIT-Rotor-Ø5-12.1	Thick magnet, w/o cooling fan, magnet hole 5, O.D. of the magnet:12.1mm
	30820010	XERUN-BANDIT-Rotor-Ø5-12.3-Ultra	Thick magnet, w/o cooling fan, magnet hole 5, O.D. of the magnet:12.3mm